

Klik-Lok™ Plastic Rivet Setter/M48000

This plastic rivet setter delivers the extra-long pulling stroke needed to set plastic rivets. Its all-steel construction and full-size handles make for smooth easy operation. The tool is packaged in a reusable, heavy-duty vinyl pouch. Weight: .6 lb.



Klik-Lok™ Plastic Rivet Kit/M48001

You'll be all set for the next job that requires plastic rivet fastening with this kit. The kit includes the M48000 Plastic Rivet Setter and a 20-pack each of our four most popular rivet sizes: No. M58106, M58108, M58149 and M58150. A reclosable carton provides storage for rivets and tool. Weight: 1.5 lbs.

Klik-Lok™ KL-2 Plastic Rivet Setter/ M48005

This long-reach tool is just what today's professional needs for hard-to-reach spots, especially in automotive applications such as flexible bumpers, wheel wells, license plate brackets and bumper reinforcements. In addition to the tool's long reach, it offers one-stroke setting and a universal nosepiece that sets all plastic rivets. The tool is packaged in a reusable, heavy-duty vinyl pouch. Weight: .75 lb.



Professional Plastic Rivet Kit/M48006

This kit includes the versatile KL-2 Plastic Rivet Setter, plus a 20-pack each of our four most popular rivet sizes: No. M58106, M58108, M58149 and M58150. A reclosable carton provides storage for rivets and tool. Weight: 1.5 lbs.

Hand Rivet Tools



HP-2®/M39000

The HP-2 is the number one selling hand rivet tool in the industry. Known and trusted for durability, quality and performance, the HP-2 is often copied but never duplicated. Its square shoulder fulcrum pin of cold-formed heat-treated steel prevents pin rotation that can elongate the engaging holes and cause premature tool failure in imitation tools. Other quality features include: precision die-cast, high-strength aluminum alloy body; drop-forged carbon steel upper handle; and thick, cushion-molded vinyl grips for comfort. The HP-2 sets up to 3/16" steel rivets and comes with four mounted nosepieces (3/32", 1/8", 5/32" and 3/16") and a service wrench. Refer to the Riveter Capacity Chart on page 19 for specific capabilities. Weight: 1.2 lbs.

HP-3®/M39002

Our newest tool offers long, ergonomically designed handles to increase leverage. The tool is spring loaded to secure the rivet in the nosepiece while the tool is in any position. The HP-3 offers powerful riveting capacity with 4 standard nosepieces to set 3/32", 1/8" and 5/32" in all alloys and up to 3/16" in steel. It features a drop-forged steel handle with heat-treated aluminum body with steel insert, high quality powder coated finish, special alloy steel fulcrum pin with anti-wearing design, and durable jaws and jaw case. Weight: 1.2 lbs.



Klik-Turn™ SP-1/M39005

The SP-1 swivel head hand-held rivet tool features a patented positive-ratchet locking feature which will allow the swivel head section of the tool to turn 360° and hold in place in any of the forty-plus positions. The high-strength steel body and cast aluminum head complement this new design in a swivel head riveting tool. The SP-1 also includes built-in threaded nosepiece storage holes and a service wrench. The SP-1 sets up to 3/16" steel rivets. Weight: 1.2 lbs.



200 Kit™/M39001

The deluxe hand riveter kit includes the HP-2 and 200 assorted Klik-Fast rivets: 50 each SB4-2, SB4-4, AB4-2A; 25 each SC4-4, AB6-2. The molded plastic case houses and protects the tool and rivets. Weight: 4 lbs.

Stainless Steel Kit/M39003

This kit is the same as our M39001, but contains 200 assorted Klik-Fast stainless steel rivets: 40 each SSB4-2S, SSB4-3S, SSB4-4S, SSBL4-2S, SSBL4-4S. Weight: 4 lbs.

Big Daddy®/M39031

The Big Daddy is the most versatile and powerful Marson brand hand riveter, taking the hard work out of setting large diameter blind rivets. Its extra-long handles provide excellent leverage and permit working a foot beyond natural reach. Other features include a patented bearing design, self-adjusting two-piece jaws and single-unit body construction with a steel insert to provide stronger threads for the nosepieces included. In addition, the Big Daddy features a double-gear reduction system which easily sets from 1/8" to 1/4" diameter Klik-Fast rivets in all alloys, including 1/4" Klik-Split® and 3/16" and 1/4" Klik-Lock™* rivets. And a one-piece collet case eliminates the need to adjust the tool when changing rivet diameters. The Big Daddy model # M39031 comes with 5/32", 3/16" and 1/4" nosepieces which are stored in the body. Weight: 3.75 lbs.

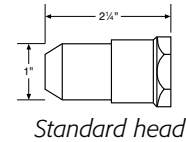

Big Daddy/M39035

This is the same tool as M39010, but comes with M39009 attached, extending the tool's reach by an additional 2 1/2". Weight: 4 lbs.



Big Daddy/M39010

This is the same tool as M39031, but comes with 3/16", 1/4" and special 1/4" Klik-Split rivet nosepieces. Weight: 3.75 lbs.

Big Daddy II/M39032

With all the features of the Big Daddy, Big Daddy II includes a built-in mandrel collection receptacle; just remove the end cap on the bottom handle to discard the spent mandrels.

Big Daddy Conversion Kit 3 Jaw Set Up/M96050

Converting to a three-jaw set adds additional gripping power and extends jaw life.



Big Daddy Extended Nosepiece Kit/M39009

Install kit to add an additional 2-1/2" to any Big Daddy Tool. Weight: .25 lb.

Hand Rivet Tool Capacity Chart

	Steel					All Aluminum					Aluminum Steel					Stainless					Mono-bolt®*		"T" Rivets		
	3/32"	1/8"	5/32"	3/16"	1/4"	3/32"	1/8"	5/32"	3/16"	1/4"	3/32"	1/8"	5/32"	3/16"	1/4"	3/32"	1/8"	5/32"	3/16"	1/4"	3/16"	1/4"	3/16"	1/4"	
HP-2/M39000	•	•	•	•		•	•	•	•		•	•	•	•		•	•	•	•						
HP-3/M39002	•	•	•	•		•	•	•	•		•	•	•	•		•	•	•	•						
SP-1/M39005	•	•	•	•		•	•	•	•		•	•	•	•		•	•	•	•						
BIG DADDY (All)		•	•	•	•	•	•	•	•	•	•	•	•	•	•	•	•	•	•	•	•	•	•	•	•

Hand Rivet Tools – Standard & Special Nosepieces

	Sizes				Monobolt®*		T-Rivet Sizes		
	3/32"	1/8"	5/32"	3/16"	1/4"	3/16"	1/4"	3/16"	1/4"
HP-2/M39000	M39131	M39128	M39130	M39129					
HP-3/M39002	M39131	M39128	M39130	M39129					
SP-1/M39005	M39160	M39161	M39163	M39162					
BIG DADDY (All)		M96024	M96025	M96026	M96027	M96031	M96030	M96029	M96028

* When setting Marson brand Klik-Lock rivets, no special nosepiece is required.

Air/Hydraulic Tools

These next-generation, professional-series air/hydraulic riveters are designed to be light weight and well-balanced. Both are engineered to maximize stroke and pull force with a 3-jaw set. For added convenience, you can direct connect or use the attached swivel. Each tool is supplied with nosepieces to set rivets in all alloys, and comes complete with adjustment service wrenches, hydraulic fluid, fluid applicator, spare jaws, and a removable swivel air connection line with an air OFF/ON valve built in. An adjustable vacuum system control allows you to control the force of air needed to hold the rivet in place. Or, you may operate with the vacuum system turned off. Recommended air pressure is 70-95 PSI.



NEW

MP-3V/M39045

Stroke: 3/4"
Pulling Force: 1,800 lbs.
Capacity: 3/32" – 3/16", all alloys
Weight: 2.9 lbs.



NEW

MP-4V/M39048

Stroke: 1"
Pulling Force: 3,420 lbs.
Capacity: 5/32" – 1/4", all alloys, 1/4" monobolt nosepiece included
Weight: 3.7 lbs.

Each of these proven, professional tools features a one-piece molded frame and front swivel air inlet for maximum operator comfort and durability. An external vacuum adjustment offers convenient air flow control for rivet placement and mandrel disposal. This allows the operator to install rivets in any orientation using one hand, and freeing up the other for assembly. Spent mandrels are conveniently collected in the bottle for disposal, encouraging a safer, clean work environment. Tools come complete with oil, replacement jaws, and nosepieces. Recommended air pressure: 85-95 psi.



302-E/M39062

Stroke: .812"
Pulling Force: 2,000 lbs.
Capacity: 3/32" – 3/16" diameter in all alloys and up to 1/4" in aluminum/steel combinations.
Weight: 4 lbs.



304-E/M39064

Stroke: 1"
Pulling Force: 4,200 lbs.
Capacity: 3/16" to 1/4" all alloys including structural rivets
 Also included are 3/16" and 1/4" Monobolt® & Magna-lok assemblies.
Weight: 5.5 lbs.



Extended head accessory for 302-E and 304-E

Tool	Description	Part Number
302-E/M39062	5" Extension Head	M88082
302-E/M39062	8" Extension Head	M88086
304-E/M39064	5" Extension Head	M88220-39
304-E/M39064	5" Extension Head	M723358

171 New Style

Air/Hydraulic Rivet Tools – Standard & Special Nosepieces

			Standard			T-Rivets / Klik-Split® 1/4"	Monobolt®**	
	3/32"	1/8"	5/32"	3/16"	1/4"		3/16"	1/4"
MP-3V/M39045	M95200	M95201	M95202	M95203				
MP-4V/M39048			M95300	M95301	M95302		M95299	M95303
302-E/M39062	M717006	M717001	M717002	M717003	M717005			
304-E/M39064				M88220-1	M88220-79	M88220-83	M88220-85	M88220-84

*For Monobolt® structural rivets, the noted special nosepiece is required. For Marson brand Klik-Lock® structural rivets, no special insert is required.

Air/Hydraulic Rivet Tools – Capacity Chart

	Steel					All Aluminum					Aluminum Steel					Stainless					Structural*		"T" Rivets		
	3/32"	1/8"	5/32"	3/16"	1/4"	3/32"	1/8"	5/32"	3/16"	1/4"	3/32"	1/8"	5/32"	3/16"	1/4"	3/32"	1/8"	5/32"	3/16"	1/4"	3/16"	1/4"	3/16"	1/4"	
MP-3V/M39045	•	•	•	•		•	•	•	•		•	•	•	•		•	•	•	•						
MP-4V/M39048			•	•	•			•	•	•			•	•	•			•	•	•	•	•			
302-E/M39062	•	•	•	•		•	•	•	•	•	•	•	•	•	•	•	•	•	•						
304-E/M39064				•	•				•	•				•	•				•	•	•	•	•	•	•

*For Monobolt® structural rivets, the noted special nosepiece is required. For Marson brand Klik-Lock® structural rivets, no special insert is required.

Air/Hydraulic Rivet Tools – Dimensions

Tool	A	B	C	D	E	F	G	WT
MP-3V/M39045	10.000"	3.500"	1.500"	3.500"	6.500"	.750"	2.750"	2.9 lbs.
MP-4V/M39048	12.000"	5.500"	2.000"	4.500"	7.000"	.750"	3.500"	3.7 lbs.
302-E/M39062	11.125"	5.000"	2.375"	4.500"	13.000"	.828"	2.500"	4 lbs.
304-E/M39064	13.125"	6.000"	2.375"	5.250"	13.000"	.938"	2.500"	5.5 lbs.

Air/Hydraulic Rivet Tools – Specifications

Tool	Work Force	Stroke
MP-3V/M39045	70-95 psi 1,800 lbs./8007 n	.750 19 mm
MP-4V/M39048	70-95 psi 3,420 lbs./15,213 n	1.000 25.4 mm
302-E/M39062	85-95 psi 2,000 lbs./8,896 n	.812" 21 mm
304-E/M39064	85-95 psi 4,200 lbs./18,682 n	1.000" 25.4 mm

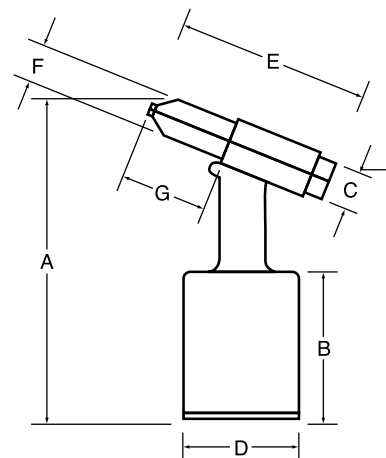

Alcoa Fastening Systems



For more than 120 years, the name Alcoa has been recognized worldwide as a strong leader in product quality and customer support. These strengths are found in every product manufactured for Alcoa Fastening Systems, offering the greatest breadth and depth of fastening system solutions in the industry.

Alcoa Fastening Systems (AFS) maintains company offices in the United States and in many other countries. AFS fastener distributors are also located in many of the world's industrial centers, where they provide a ready source of AFS fasteners, installation tools, tool parts, and application assistance.

Americas

Industrial Fastener Division
8001 Imperial Drive
Waco, TX 76712, USA
P.O. Box 8117
Waco, TX 76714-8117, USA
Tel: 800 388 4825
Fax: 800 798 4825

Installation Tool Division
1 Corporate Drive
Kingston, NY 12401, USA
Tel: 800 278 4825
Fax: 845 334 7333

AFS Industrial Distribution
Group Headquarters
1925 North MacArthur Drive
Tracy, CA 95376, USA
Tel: 209 839 3000
Fax: 209 839 3022

AFS Industrial
Distribution Group
5436 West 78th Street
Indianapolis, IN 46268, USA
Tel: 800 826 2884
Fax: 800 573 2645

Latin America Sales
Avenida Parque Lira
79-402 Tacubaya
Mexico C P 11850, USA
Tel: +52 55 5515 1776
Fax: +52 55 5277 7564

International Locations

India Operations
Level 6, Constantia 11
U.N. Brahachari Street
Kolkata 700,017 WB India
Tel: +91 33 4400 0612
Fax: +91 33 4400 0555

Japan/Korea Sales
Alcoa Japan Ltd.
#1013 NBF Hibiya Bldg.
Uchisaiwai-cho, Chiyoda-ku
Tokyo 100-1011
Phone: +81 3 3539 6577
Fax: +81 3 3539 6585

Melbourne Operations
1508 Centre Road
Clayton, Victoria, 3168
Australia
Tel: +61 3 8545 3333
Fax: +61 3 8545 3390

Shanghai Sales
Area A2, 1st Floor
No. 205 Taigu Road
Waigaocqiao Free Trade Zone
Shanghai, 200131, China
Tel: +86 21 5866 5080
Fax: +86 21 5868 1859

Telford Operations
Unit C, Stafford Park 7
Telford, Shropshire TF3, 3BQ
United Kingdom
Tel: +44 1952 2900 11
Fax: +44 1952 2904 59

Alcoa Fastening Systems
St Cosme Operations
9 rue de Cressonnieres
72110 Saint Cosme en Varais
France
Tel: +33 0 2.43.31.41.00
Fax: +33 0 2.43.31.41.41

Alcoa Fastening Systems
Kelkheim Operations
Industriestr. 6
65779 Kelkheim
Germany
Tel: +49 0 6195 8050
Fax: +49 0 6195 2001

alcoafasteners.com
afs-idg.com

Disclaimer:

The information contained in this publication is only for general guidance, and is not intended to create any warranty, express, implied, or statutory; all warranties are contained only in AFS's written quotations, acknowledgments, and/or purchase orders. It is recommended that the user secure specific, up-to-date data and information regarding each application and/or use of such products.

**Alcoa
Fastening
Systems**

